



Exergetic Comparison of Single and Double Effect Absorption Cooling Cycles

Tek ve Çift Etkili Absorpsiyonlu Soğutma Çevrimlerinin Ekserji Yönünden Karşılaştırılması

Rabi Karaali

Bayburt University, Faculty of Engineering, Mechanical Engineering Department, Bayburt, Turkey

Abstract

Absorption cooling cycles are environmental and can use solar or waste heat for cooling with very small electric power. This work presents exergy analysis of a double effect parallel flow and single effect absorption cooling systems for comparison. A computer program is developed for the thermodynamic properties of lithium bromide-water solutions by the author in FORTRAN codes for the exergy analysis. The double effect parallel flow absorption systems have better advantages than the single effect absorption system. The coefficient performance (COP) and the exergetic coefficient performance (ECOP) of the double effect parallel flow absorption systems are higher than the single cycles. For the double effect cycle COP and ECOP are found as 1.195 and 0.28, and for the single effect cycle COP and ECOP are found as 0.68 and 0.23, respectively. For each component the exergy loss and exergy destruction is calculated. Most of the irreversibilities are found in the evaporator and in the absorber which about 74 % for the double effect, and 72 % for the single effect of the total irreversibility. It is concluded that the performance of the evaporator and the absorber is crucial for the two cycles. Improving and better design of these two components will directly improve and affect positively the working conditions and the performance of the cycles.

Keywords: Absorption, Cooling, ECOP, Single-Double effect

Öz

Absorpsiyonlu soğutma çevrimleri, çevreci ve atık ısı yada güneş enerjisi kullanabilen, çok az elektrik gücü gerektiren çevrimlerdir. Bu çalışmada, karşılaştırma için tek etkili ve çift etkili paralel akışlı soğutma çevrimlerinin ekserji analizi sunulmuştur. Lityum bromid su çözeltisinin termodinamik özelliklerini hesaplamak ve ekserji analizinde kullanmak için yazar tarafından FORTRAN dilinde bir bilgisayar programı geliştirilmiştir. Çift etkili paralel akışlı soğutma çevrimleri performans yönünden tek etkili çevrimlerden daha avantajlıdır. Çift etkili paralel akışlı soğutma çevrimlerinin performans katsayısı (COP) ve ekserjetik performans katsayısı (ECOP), tek etkili soğutma çevrimlerinden daha yüksektir. Çift etkili soğutma çevrimi için COP ve ECOP sırasıyla 1.195 ve 0.28, tek etkili soğutma çevrimi için ise COP ve ECOP sırasıyla 0.68 ve 0.23 bulunmuştur. Çevrimlerin her bir elemanı için ekserji kayıpları ve tersinmezlikleri hesaplanmıştır. Tersinmezliklerin, çift etkili çevrimde % 74 ve tek etkili çevrimde % 72'sinin yani çoğunun evaporator ve absorberde meydana geldiği görülmüştür. Evaporator ve absorber performansının bu iki çevrim için hayati önemde olduğu anlaşılmıştır. Bu iki elemanın geliştirilmesi ve daha iyi dizayn edilmesi çevrimlerin çalışma şartlarını iyileştirecek ve performansını olumlu yönde etkili bir şekilde artıracaktır.

Anahtar Kelimeler: Absorpsiyon, Soğutma, ECOP, Tek ve çift etkili

Nomenclature

COP	coefficient of performance
e	specific exergy (kJ/kg)
\dot{E}	exergy flow rate (kW)
h	specific enthalpy (kJ/kg), (kJ/kMol)
\dot{m}	mass flow rate (kg/s)
P	pressure (kPa)
\dot{Q}	heat flow rate (kW)

s	specific entropy (kJ/kg K)
T	temperature (K)
\dot{W}	power (kW)

Greek letters

η	efficiency
--------	------------

Subscripts

A	absorber
C	condenser
D	destruction
en	energy

ex	exergy
E	evaporator
EXV	expansion valve
HE	heat exchanger
HPG	high pressure generator
L	loss
LPG	low temperature generator
OC	overall cycle
P	pump
tot	total
0	environment conditions

*Corresponding Author: rabikar@gmail.com

Received / Geliş tarihi : 10.08.2016

Accepted / Kabul tarihi : 27.10.2016

1. Introduction

There is a growing need for building cooling and refrigeration in industry all over the world, in a foreseeable future. The increasing requirements for comfort, higher living standards and the increasing thermal load of buildings, are the main causes of this growing. For the refrigeration cycles using low temperature waste heat, geothermal or solar energy can reduce power consumption for cooling. For cooling and refrigeration at over 0 °C temperature of evaporator, absorption chillers using LiBr-H₂O solution offer very good efficiency than the other solutions. But there is a risk of salt crystal formation called solution crystallization that happens when there is low ambient temperature or high absorber temperature, and air leak into machine. For producing cold at temperatures below than 0 °C, ammonia-lithium nitrate, the ammonia-water solution, or other appropriate solutions can be used better. The COP of an absorption cycle depends on three external temperatures; ambient, generation (driving) and evaporation temperatures. The triple effect cycle has the best COP among the half effect, the single effect, and the double effect cycles. The half effect cycles has the lowest COP, the single effect cycle presents better COP than the half one. However, the double effect cycle has better COP than the single one. The details of these cycles, their differences and their configuration can be found in literature. The double and the single effect absorption cycles have more commercial use than the half one and triple one (Avanessian and Ameri 2014, Inzunza et al. 2014). The air cooled double effect systems are better than the single one because they are more efficient, flexible, without cooling tower and independence upon water.

The same driving heat source produces refrigerant vapor twice in double effect cycle that in these process two vapor generators are needed. Between in lots of configuration of double effect cycles are obtained, the most common ones are in-parallel and in series cycle layouts. In series means that without dividing into two streams the entire flow goes through both generators. In parallel cycle the solution flow going to the high pressure generator does not go to the lower pressure generator. The solution stream split among both. The in-parallel layouts have higher COP; however in-series layouts are better in the cooling capacity than the in-parallel layouts (Inzunza et al. 2014).

Li et al. (2014) have done a performance analysis of solar air cooled double effect LiBr/H₂O absorption cooling system in subtropical city. They found that increasing the collector temperature was decreasing the performance. Gomri and

Hakimi (2008) have done the second law analysis of double effect vapor absorption cooler system and they obtained that increasing low pressure generator temperature increases the performance of the system and the highest exergy losses occurs in high pressure generator and absorber. Ventas et al. (2016) studied on two-stage double-effect ammonia/lithium nitrate absorption cycle and they concluded that maximum COP is about 1.25. Colorado and Rivera (2015) have obtained the performance comparison between a conventional vapor compression and compression-absorption single-stage and double-stage systems used for refrigeration. They concluded that the compression power of the cascade cycles was 45 % lower than in compression cycles.

Avanessian and Ameri (2014) have done the energy, exergy, and economic analysis of single and double effect LiBr-H₂O absorption chillers. They showed that the double effect absorption chillers are more economical than the single effect. Talukdar and Gogoi (2016) have done the exergy analysis of a combined vapor power cycle and boiler flue gas driven double effect water-LiBr absorption refrigeration system. They concluded that for integration with power cycle, the double effect absorption system is more appropriate and better than the single effect. Farshi et al. (2013) studied on exergo-economic analysis of double effect absorption refrigeration systems, and they found that lower total investment costs were obtained when the condenser temperatures were low and the evaporator temperatures were high. Bouaziz and Lounissi (2015) in their study named the energy and exergy investigation of a novel double effect hybrid absorption refrigeration system for solar cooling, they found that the COP of the proposed system is better than the conventional one. Kaynakli et al. (2015) have done the energy and exergy analysis of a double effect absorption refrigeration system based on different heat sources; they have reported that higher temperatures of the heat sources increases the exergy destruction of the high pressure generator.

Cimsit et al. (2015) have studied on the thermo-economic optimization of LiBr/H₂O-R134a compression absorption cascade refrigeration cycle. They found that the cascade cycle has the potential to reduce electric energy consumption about 50 %. Inzunza et al. (2014) have done the comparison of the performance of single-effect, half-effect, double-effect in series and inverse absorption cooling systems operating with the mixture H₂O/LiBr. They found that for the generation temperature between 100 °C and 110 °C, the COP of the single effect was up to 0.89, for the generation

temperature of over 55 °C the COP of the half effect was up to 0.44. They also found that the most efficient one is the double effect systems, which the COP is up to 1.48. They observed that for low temperatures the half effect systems work better than any other. Inzunza et al. (2014) also studied the comparison of the performance of single-effect, half-effect, double-effect in series and inverse and triple-effect absorption cooling systems operating with the $\text{NH}_3\text{-LiNO}_3$ mixture. They obtained that the COP values of $\text{H}_2\text{O/LiBr}$ are higher than the COP values of $\text{NH}_3\text{-LiNO}_3$; however the evaporator temperature can be as low as -50 °C with $\text{NH}_3\text{-LiNO}_3$ refrigeration solution.

The goal of this study is to investigate and compare the irreversibility and the exergetic coefficient of performance (ECOP) of the double effect parallel flow absorption system, and the single effect absorption system. The two cycles and their working conditions is taken from the reference (ASHRAE 2001).

2. Materials and Method

The schematic diagram of a single effect absorption system is given in Figure 1. A single effect absorption system consists of an absorber, a condenser, a generator, an evaporator, a heat exchanger, a pump and two expansion valves. The cycle has a refrigerant cycle (7-10) and $\text{H}_2\text{O-LiBr}$ solution cycle (1-6). The generator is supplied with a heat source and $\text{H}_2\text{O-LiBr}$ solution is located in high pressure in the generator. The evaporated H_2O is conducted to the condenser. The condenser gives heat to the atmosphere to change the phase of H_2O from vapor to liquid. In order to reach the evaporation pressure the refrigerant H_2O is expanded in a expansion valve. The cooling process is obtained in the evaporator when the refrigerant absorbs heat from the environment. The refrigerant evaporates again and then is conducted to the absorber. The vapor is mixes with $\text{H}_2\text{O-LiBr}$ solution coming from the generator and the absorber releases heat. After that the weak $\text{H}_2\text{O-LiBr}$ solution is pumped to the generator by passing through the heat exchanger which increases solution temperature. The cycle starts once again in the generator. Some of the refrigerant evaporates and goes to the condenser; the rest of the solution is led to the heat exchanger to decrease its temperature. Then passes a throttle valve to reduce the pressure until evaporation pressure and finally it comes to the absorber.

The schematic diagram of a double effect parallel flow absorption system is given in Figure 2. The solution that is pumped from the pump1 is heated in the heat exchanger2

and firstly enters the low pressure generator which is heated by the condenser1, after that the liquid solution is pumped with pump2 to the heat exchanger1 and then enters the high pressure generator. The vapor taken from the high pressure generator, condensates in the condenser1 and some of the heat energy is transferred into the low pressure generator. The liquid enters condenser2 and mixes with the

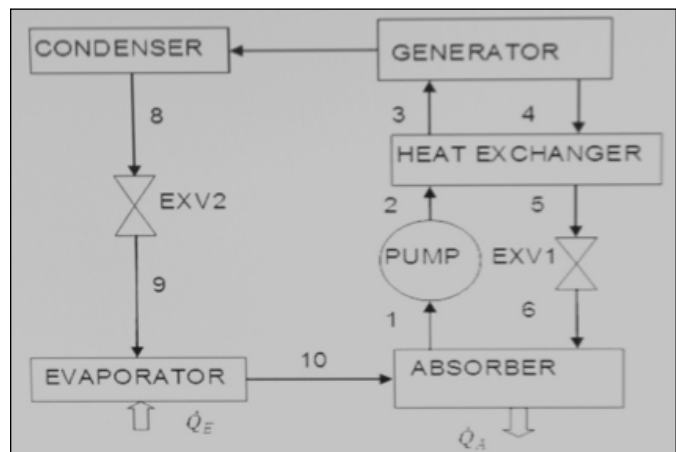

Figure 1. Schematic diagrams of a single effect absorption system.

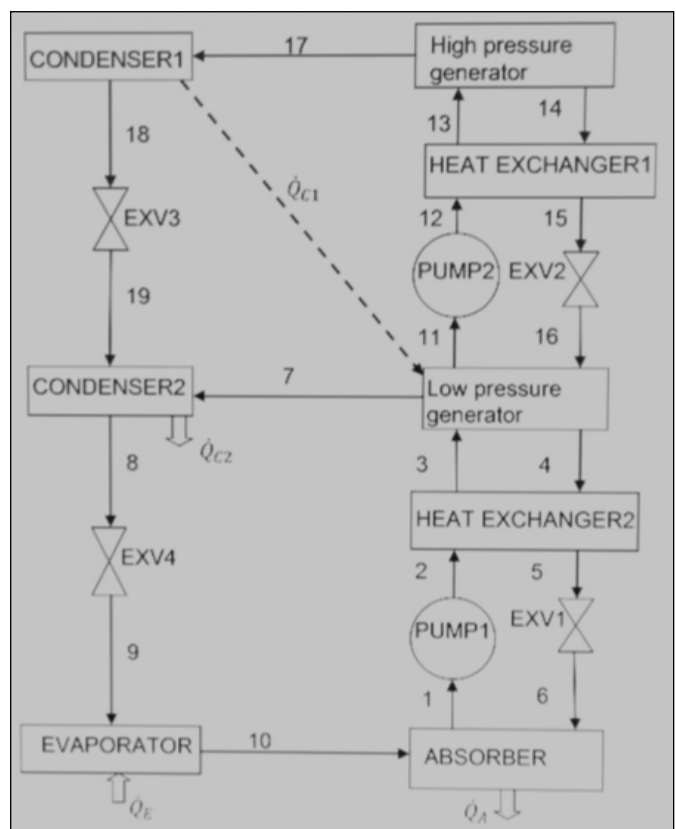

Figure 2. Schematic diagrams of a double effect (parallel flow) absorption system.

vapor coming from the low pressure generator. After that the liquid transferred from the expansion valve4 evaporates in the evaporator to obtain cooling.

In this study the thermodynamic analysis of the cycles which is given in figure 1 and 2 are done and the thermodynamic and the mathematical modeling are explained as follows. The chemical exergy of the streams are not taken into calculation because, there is no mass inlet or outlet of the cycle. The physical exergy of the streams is taken as the total exergy. The equations of the calculation of the cycle are given in Table 1 for of each component and for overall cycle.

In this study, these assumptions are utilized in the analysis of the cycle: The cycle is at steady state and steady flow cycle, the pump process is adiabatic, the pressure reducing valve is an adiabatic process, pressure drops in the pipeline and in the components are neglected, refrigerant leaving the condenser is saturated liquid at condenser pressure, solution leaving the generators and the absorber are assumed to be saturated in equilibrium conditions at its respective temperature and pressure, refrigerant leaving the evaporator is saturated

vapor at evaporator pressure, refrigerant is pure water, direct heat transfer from the components to the surroundings is negligible.

3. Results and Discussion

A computer program written by the author in FORTRAN codes is used to calculate the enthalpy and entropy values of the streams. To calculate the enthalpy and the entropy values of the streams the equations used in the program are taken from the reference (Chua et al. 2000, Kaita 2001). However, the reference state values are taken at 100 kPa pressure, 25 °C temperature, and for 50 % concentration H₂O-LiBr, as h₀=49.2 kJ/kg and s₀=0.1867 kJ/kgK for the mixture of H₂O/LiBr.

In Table 2 for each stream of the single effect cycle, the fluids, the pressures, the temperatures, the concentrations, the flow rates values, the enthalpies, the entropies, the exergy, and the energy, the heat exergy, the destructed exergy of each component, COP, ECOP, the exergy and the energy balance are given. In Table 3 for each component of the double

Table 1. For of each component and for overall cycle mass, energy, and exergy equations (Annamalai and Puri 2002., Dincer and Rosen 2007).

Component	Mass Equation	Energy Equation	Exergy Equation
Pump	$\dot{m}_1 = \dot{m}_2$	$W_{P1} = \dot{m}_1(h_2 - h_1)$	$E_1 = \dot{m}_1(h_1 - h_0 - T_0(s_1 - s_0))$ $E_2 = \dot{m}_2(h_2 - h_0 - T_0(s_2 - s_0))$
Heat exchanger	$\dot{m}_2 = \dot{m}_3$ $\dot{m}_4 = \dot{m}_5$	$\dot{m}_2 h_2 + \dot{m}_4 h_4 = \dot{m}_3 h_3 + \dot{m}_5 h_5$	$E_3 = \dot{m}_3(h_3 - h_0 - T_0(s_3 - s_0))$ $E_4 = \dot{m}_4(h_4 - h_0 - T_0(s_4 - s_0))$ $E_5 = \dot{m}_5(h_5 - h_0 - T_0(s_5 - s_0))$
Expansion Valve1	$\dot{m}_5 = \dot{m}_6$	$\dot{m}_5 h_5 = \dot{m}_6 h_6$	$E_6 = \dot{m}_6(h_6 - h_0 - T_0(s_6 - s_0))$
Generator	$\dot{m}_3 = \dot{m}_4 + \dot{m}_7$	$\dot{m}_3 h_3 + Q_G = \dot{m}_4 h_4 + \dot{m}_7 h_7$	$E_7 = \dot{m}_7(h_7 - h_0 - T_0(s_7 - s_0))$
Condenser	$\dot{m}_7 = \dot{m}_8$	$\dot{m}_7 h_7 = \dot{m}_8 h_8 + Q_c$	$E_8 = \dot{m}_8(h_8 - h_0 - T_0(s_8 - s_0))$
Expansion Valve2	$\dot{m}_8 = \dot{m}_9$	$\dot{m}_8 h_8 = \dot{m}_9 h_9$	$E_9 = \dot{m}_9(h_9 - h_0 - T_0(s_9 - s_0))$
Evaporator	$\dot{m}_9 = \dot{m}_{10}$	$\dot{m}_9 h_9 + Q_E = \dot{m}_{10} h_{10}$	$E_{10} = \dot{m}_{10}(h_{10} - h_0 - T_0(s_{10} - s_0))$
Absorber	$\dot{m}_6 + \dot{m}_{10} = \dot{m}_1$	$Q_A = \dot{m}_{10} h_{10} + \dot{m}_6 h_6 - \dot{m}_1 h_1$	
Overall cycle		$(\dot{Q}_A + \dot{Q}_C)_{outletenergy}$ $= (Q_G + W_P + \dot{Q}_E)_{inletenergy}$ $COP = \dot{Q}_E / (W_P + \dot{Q}_G)$ $W_P = \dot{m}_{in}(h_{in} - h_{out}) = \Delta P / \rho$ $\dot{E} = Q \left(1 - \frac{T_0}{T}\right)$ $\dot{E}_{D,G} = \dot{E}_3 + \dot{E}_G - \dot{E}_7 - \dot{E}_4$	$\dot{E}_{D,C} = \dot{E}_7 - \dot{E}_8 - \dot{E}_{C1}$ $\dot{E}_{D,HE} = \dot{E}_2 + \dot{E}_4 - \dot{E}_3 - \dot{E}_5$ $\dot{E}_{D,E} = \dot{E}_9 + \dot{E}_E - \dot{E}_{10}$ $\dot{E}_{D,EXV} = \dot{E}_{in} + \dot{E}_{out}$ $ECOP = \dot{E}_E / (W_{P,tot} + \dot{E}_G)$

effect cycle, the exergy, and the energy, the heat exergy, the destructed exergy of each component, COP, ECOP, the exergy and the energy balance are given.

As can be seen that for the overall single effect cycle the total destructed and lost exergy is about 974.3 kW, and the 370.5 kW of it is destructed at the evaporator that means 38 % of the total destructed exergy. For the overall double effect cycle the total destructed and lost exergy is about 572 kW, and the 253 kW of it is destructed at the evaporator that means 44 % of the total destructed exergy. The total destructed and lost exergy in the absorber of the double

effect cycle is found as 174 kW, and that is 30 % of the total destructed exergy. For the single effect cycle that is found as 193.3 kW, and that is about 34 % of the total destructed and lost exergy. For the single effect cycle in the evaporator and in the absorber 72 % of the total exergy is destructed and lost while for the same components of the double effect cycle this rate is about 74 %. That means the efficiency of the absorber and the evaporator is crucial for the cycle. Improving and better design of these two components will directly affect and improve the working conditions and the performance of the overall cycle.

Table 2. Thermodynamic properties of the streams of the single effect absorption cycle.

Stream Nu.	Fluid	Pressure kPa	Temperature °C	Concentration kgNH ₃ /kgmix	Flow rate Kg/s	Enthalpy kJ/kg	Entropy kJ/kgK	Exergy kW
0	LiBr/H ₂ O	100	25	50	-	49.2	0.1867	-
1	Weak LiBr/H ₂ O	0.697	40.7	59.6	11.99	115.02	0.2359	613.3
2	Weak LiBr/H ₂ O	10.2	40.7	59.6	11.99	115.02	0.2359	613.3
3	Weak LiBr/H ₂ O	10.2	76.1	59.6	11.99	183.03	0.4401	698.8
4	Strong LiBr/H ₂ O	10.2	103.5	64.6	11.06	257.75	0.5425	1133.3
5	Strong LiBr/H ₂ O	10.2	62.4	64.6	11.06	184.02	0.3354	1000.8
6	Strong LiBr/H ₂ O	0.697	49.9	64.6	11.06	184.02	0.3360	1222
7	H ₂ O	10.2	103.5	0	0.93	2690.1	8.466	160.4
8	H ₂ O 10.2		46.2	0	0.93	193.34	0.654	4.5
9	H ₂ O	0.697	1.8	0	0.93	193.34	0.68	-2.7
10	H ₂ O	0.697	1.8	0	0.93	2503	9.11	-192.2
Absorber heat energy- exergy destruction					$Q_A = 2984$ kW, $E_A = 62.6$ kW, $E_{D,A} = 130.7$ kW,			
Pump work energy					$W_P = 0.006$ kW			
Condenser heat energy-exergy--exergy destruction					$Q_C = 2322$ kW, $E_{C,lost} + E_{D,C} = 156$ kW			
Expansion valve1,2 exergy destruction					$E_{D'EXV1} = 2$ kW, $E_{D,EXV2} = 7.2$ kW			
Heat Exchanger--exergy destruction, Exergy efficiency					$E_{D,HE1} = 47$ kW			
Evaporator heat energy- exergy					$Q_E = 2148$ kW, $E_E = 181$ kW, $E_{D'E} = 370.5$ kW			
Generator heat energy- exergy					$Q_G = 3158$ kW, $E_G = 793.2$ kW, $E_{D'G} = 198.3$ kW			
COP					0.68			
ECOP					0.23			
Inlet Energy=Outlet Energy $\rightarrow (W_P + Q_G + Q_E = Q_A + Q_C) \rightarrow (0.006+3158+2148=2984+2322) \rightarrow 5306=5306$								
Overall Cycle(inlet exergy ($E_{OC} = E_G + W_P + E_E = 793.2+0.006+181=974.2$))								
Overall Cycle(inlet exergy=outlet exergy=Lost + Destructed)								
$E_{Loss,OC} = E_{Loss,A} + E_{Loss,C} = 62.6+154=216.6$ kW								
$(E_{D,OC} = E_{D,C} + E_{D,A} + E_{D'HE} + E_{D,G} + E_{D'E} + E_{D,EX1,2} = 2+130.7+47+198.3+370.5+9.2=757.7)$								
inlet exergy=outlet exergy $974.2=757.7+216.6 \rightarrow 974.2 \approx 974.3$)								

The condenser2 of the double effect cycle has high destructed and lost exergy that is about 71 kW and that is 12 % of the total lost and destructed exergy. The condenser of the single effect cycle also has high destructed and lost exergy that is about 156 kW and that is 16 % of the total lost and destructed exergy. For the two cycles the irreversibility in the heat exchangers, in the expansion valves and in the pumps is small, but they are taken into calculation.

The most important thing to evaluate a refrigeration system is the coefficient performance (COP) and the exergetic coefficient performance (ECOP) of the cycle. The coefficient performance (COP) of the double effect cycle is 1.195 and the exergetic coefficient performance (ECOP) of the cycle is 0.28. For the single effect cycle the COP is 0.68 and the ECOP is 0.23. The operating temperature of the double effect cycle is 170.7 °C, and for the single effect cycle is 103.5 °C. The double effect cycle is required generator temperature higher than 150 °C, while the single effect cycle is required generator temperature between 80 and 110 °C. These results showed that the double effect systems have higher COP and ECOP values than the single effect systems. However the

single effect systems required fewer components to operate than the double effect one and therefore the single effect systems are less expensive and simpler than the double effect one. These results are in good agreement with the literature. 2 % Error is happened in all this calculation of the double effect cycle which can be ignored.

4. Conclusion

Absorption cooling cycles are environmental and can use solar or waste heat for cooling with very small electric power. This work presents exergy analysis of a double effect parallel flow and single effect absorption systems for comparison. A computer program is developed for the thermodynamic properties of lithium bromide-water solutions by the author in FORTRAN codes for the exergy analysis. The double effect parallel flow absorption systems have better advantages than the single effect absorption system. The coefficient performance (COP) and the exergetic coefficient performance (ECOP) of the double effect parallel flow absorption systems are higher than the single cycles. For the double effect cycle COP and ECOP are found as 1.195 and

Table 3. Energy, exergy and destructed exergy for overall and for each component of the double effect parallel flow absorption cycle.

Absorber heat energy- exergy destruction	$Q_A = 2328 \text{ kW}, E_A = E_{D,A} = 174 \text{ kW}$
Pump1 work energy	$W_{P1} = 0.043 \text{ kW}$
Pump2 work energy	$W_{P2} = 0.346 \text{ kW}$
Condanser1 heat energy-exergy--exergy destruction	$Q_{e1} = 1023 \text{ kW}, E_{C1} = 207 \text{ kW}, (E_{D,LPG} + E_{D,C1}) = 75.9 \text{ kW},$
Condanser2 heat energy-exergy--exergy destruction	$Q_{e2} = 905 \text{ kW}, E_{C2} = E_{D,C2} = 71 \text{ kW}$
Expansion valve1,2,3,4 exergy destruction	$E_{D,EXV1} = 0.4 \text{ kW}, E_{D,EXV2} = 0.3 \text{ kW}, E_{D,EXV3} = 0.8 \text{ kW},$ $E_{D,EXV4} = 0.4 \text{ kW}$
Heat Exchanger1--exergy destruction, Exergy efficiency	$E_{D,HE1} = 5.3 \text{ kW}$
Heat Exchanger2--exergy destruction, Exergy efficiency	$E_{D,HE2} = 5.4 \text{ kW}$
Evaporator heat energy- exergy	$Q_E = 1760 \text{ kW}, E_E = 126.5 \text{ kW}, E_{D,E} = 253 \text{ kW}$
High pressure generator heat energy	$Q_{HPG} = 1472 \text{ kW}, E_{HPG} = 445 \text{ kW}$
Low pressure generator heat energy exergy destruction	$Q_{LPG} = Q_{e1} = 1023 \text{ kW}, E_{LPG} = 133.9 \text{ kW}, (E_{D,LPG} + E_{D,C1}) = 75 \text{ kW}$
COP	1.195
ECOP	0.28
Inlet Energy=Outlet Energy $\rightarrow (W_{P,TOT} + Q_{HPG} + Q_E = Q_A + Q_{e2}) \rightarrow (0.3 + 1472 + 1760 = 2328 + 905) \rightarrow 3233 \approx 3232.3$	
Overall Cycle(inlet exergy ($E_{OC} = E_{HPG} + W_{P,TOT} + E_E = 445 + 0.4 + 126.5 = 572$))	
Overall Cycle(inlet exergy=outlet exergy=Lost + Destructed) ($E_{D,OC} = (E_{D,LPG} + E_{D,C1}) + E_{D,A} + E_{D,C2} + E_{D,E} + E_{D,others} = 75 + 174 + 71 + 253 + 12 = 585 \approx 572 = \text{inlet exergy}$) Error=(585-572)/572=0.02	

0.28, and for the single effect cycle COP and ECOP are found as 0.68 and 0.23, respectively. For each component the exergy loss is calculated. Most of the irreversibilities are found in the evaporator and in the absorber which about 74 % for the double effect and 72 % for the single effect of the total irreversibility. It is concluded that the efficiency of the evaporator and the absorber is crucial for the double effect and for the single effect absorption cycles. Improving and better design of these two components will directly improve and affect positively the working conditions and the performance of the cycle.

5. References

- Annamalai, K., Puri, IK. 2002.** Advanced thermodynamics engineering, CRC Press LLC.
- ASHRAE Fundamentals Handbook. 2001.** Chapter 1. Thermodynamics and refrigeration cycles.
- Avanessian, T., Ameri, M. 2014.** Energy, exergy, and economic analysis of single and double effect LiBr-H₂O absorption chillers. *Energy Build.*, 73: 26–36.
- Bouaziz, Nahla, Lounissi, D. 2015.** Energy and exergy investigation of a novel double effect hybrid absorption refrigeration system for solar cooling. *Int. J. Hydrogen Energy*, 40: 13849- 3856.
- Chua, HT., Toh, H.K., Malek, A., Ng, KC., Srinivasan, K. 2000.** Improved thermodynamic property fields of LiBr-H₂O solution. *Int. J. Refrigeration*, 23: 412-429.
- Cimsit, C., Ozturk, IT., Kincay, O. 2015.** Thermoeconomic optimization of LiBr/H₂O-R134a compression absorption cascade refrigeration cycle. *Appl. Therm. Eng.*, 76: 105-115.
- Colorado, D., Rivera, W. 2015.** Performance comparison between a conventional vapor compression and compression-absorption single-stage and double-stage systems used for refrigeration. *Appl. Therm. Eng.*, 87: 273-285.
- Dincer, I., Rosen, MA. 2007.** EXERGY, energy, environment and sustainable development, 1st ed., Elsevier Ltd.
- Farshi, GL., Mahmoudi, SMS., Rosen, MA., Yari, M., Amidpour, M. 2013.** Exergoeconomic analysis of double effect absorption refrigeration systems. *Energy Convers. Manage.*, 65: 13–25
- Gomri, R., Hakimi, R. 2008.** Second law analysis of double effect vapour absorption cooler system. *Energy Convers. Manage.*, 49: 3343–3348.
- Inzunza, DLA., Sandoval-Reyes, M., Hernández-Magallanes, J.A., Rivera, W. 2014.** Comparison of the performance of single-effect, half-effect, double-effect in series and inverse absorption cooling systems operating with the mixture H₂O/LiBr. *Energy Proc.*, 57: 2534-2543.
- Inzunza, DLA., Hernández-Magallanes, J.A., Sandoval-Reyes, M., Rivera, W. 2014.** Comparison of the performance of single-effect, half-effect, double-effect in series and inverse and triple-effect absorption cooling systems operating with the NH₃-LiNO₃ mixture. *Appl. Therm. Eng.*, 66: 612-620.
- Kaita, Y. 2001.** Thermodynamic properties of lithium bromide-water solutions at high temperature. *Int. J. Refrigeration*, 24: 374-390.
- Kaynakli, O., Saka, K., Kaynakli, F. 2015.** Energy and exergy analysis of a double effect absorption refrigeration system based on different heat sources. *Energy Convers. Manage.*, 106: 21–30.
- Li, Z., Ye, X., Liu, J. 2014.** Performance analysis of solar air cooled double effect LiBr/H₂O absorption cooling system in subtropical city. *Energy Convers. Manage.*, 85: 302–312.
- Talukdar, K., Gogoi, TK. 2016.** Exergy analysis of a combined vapor power cycle and boiler flue gas driven double effect water–LiBr absorption refrigeration system. *Energy Convers. Manage.*, 108: 468–477.
- Ventas, R., Lecuona, A., Vereda, C., Legrand, M. 2016.** Two-stage double-effect ammonia/lithium nitrate absorption cycle. *Appl. Therm. Eng.*, 94: 228–237.